

Napinacz łańcuchowy typ TEKS

kompletny

RESATEC AG

Materiał

Stal

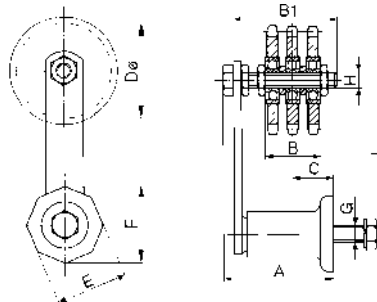
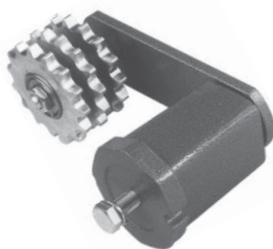

Jednorzędowy

Kod	Typ	A	B1	Regulacja C	D Ø	B	E	F	G	H	L	kg
T 18435	TEKS 3 3/8 x 7/32" - 10 S	70	60	13 - 43	45.81	9	46	48	M 8	M 10	100	0.55
T 18436	TEKS 4 3/8 x 7/32" - 10 S	85	60	28 - 57	45.81	9	56	59	M 10	M 10	100	0.65
T 18437	TEKS 4 1/2 x 5/16" - 10 S	85	60	28 - 57	61.08	9	56	59	M 10	M 10	100	0.80
T 18438	TEKS 5 5/8 x 3/8" - 12 S	116	80	40 - 82	76.36	12	72	76	M 12	M 12	130	2.30
T 10023	TEKS 5 3/4 x 7/16" - 12 S	116	80	40 - 82	91.63	12	72	76	M 12	M 12	130	2.60
T 18439	TEKS 6 3/4 x 7/16" - 20 S	152	120	38 - 102	91.63	15	93	97	M 16	M 20	175	4.60
T 18440	TEKS 6 1" x 17.02 - 20 S	152	120	38 - 102	106.14	15	93	97	M 16	M 20	175	5.00
T 44499	TEKS 7 1 1/4 x 3/4" - 20 S	210	140	76 - 156	132.67	15	106	112	M 20	M 20	220	8.50
T 44488	TEKS 7 1 1/2 x 1" - 20 S	210	160	76 - 156	135.23	15	106	112	M 20	M 20	220	8.90

Dwurzędowy

T 18441	TEKS 3 3/8 x 7/32" - 10 D	70	60	26 - 36	45.81	19.2	46	48	M 8	M 10	100	0.60
T 18442	TEKS 4 3/8 x 7/32" - 10 D	85	60	40 - 50	45.81	19.2	56	59	M 10	M 10	100	0.85
T 18443	TEKS 4 1/2 x 5/16" - 10 D	85	60	42 - 48	61.08	22.9	56	59	M 10	M 10	100	1.00
T 18444	TEKS 5 5/8 x 3/8" - 12 D	116	80	50 - 70	76.36	28.6	72	76	M 12	M 12	130	2.30
T 18445	TEKS 5 3/4 x 7/16" - 12 D	116	80	52 - 70	91.63	31.5	72	76	M 12	M 12	130	2.80
T 18446	TEKS 6 3/4 x 7/16" - 20 D	152	120	50 - 91	91.63	34.5	93	97	M 16	M 20	175	4.60
T 18447	TEKS 6 1" x 17.02 - 20 D	152	120	56 - 84	106.14	46.9	93	97	M 16	M 20	175	5.20
T 44489	TEKS 7 1 1/4 x 3/4" - 20 D	210	140	98 - 140	132.67	51.5	106	112	M 20	M 20	220	10.20
T 44490	TEKS 7 1 1/2 x 1" - 20 D	210	160	102 - 136	135.23	63.4	106	112	M 20	M 20	220	10.70

Trzyrzędowy

T 18448	TEKS 4 3/8 x 7/32" - 10 T	85	60	30 - 45	45.81	29.4	56	59	M 10	M 10	100	0.90
T 18449	TEKS 5 1/2 x 5/16" - 12 T	85	80	57 - 65	61.08	40.0	72	76	M 12	M 12	130	2.25
T 18450	TEKS 5 5/8 x 3/8" - 12 T	116	80	58 - 63	76.36	45.2	72	76	M 12	M 12	130	2.65
T 18452	TEKS 6 5/8 x 3/8" - 20 T	152	120	55 - 84	76.36	48.2	93	97	M 16	M 20	175	4.50
T 18453	TEKS 6 3/4 x 7/16" - 20 T	152	120	62 - 80	91.63	54.0	93	97	M 16	M 20	175	5.10
T 18454	TEKS 7 1" x 17.02 - 20 T	210	120	94 - 125	106.14	78.8	106	112	M 20	M 20	220	9.30
T 44492	TEKS 7 1 1/4 x 3/4" - 20 T	210	140	95 - 120	132.67	88.0	106	112	M 20	M 20	220	11.65
T 44493	TEKS 7 1 1/2 x 1" - 20 T	210	160	89 - 108	135.23	111.8	106	112	M 20	M 20	220	12.70

Rozmiary w mm.

UWAGA:

Automatyczny napinacz dla przekładni łańcuchowych, jest połączeniem uniwersalnego napinacza Typu TE z kołem łańcuchowym Typu KS. Zastosowanie w/w napinacza przedłuży żywotność łańcucha i zapewnia jego równomierną pracę, co eliminuje nadmierny hałas i wibracje przekładni. Koła łańcuchowe stalowe ocynkowane osadzone są na łożyskach kulowych o podwyższonej żywotności.

Napinacz łańcucha Typ TECRS

kompletny



Material

Stal/Vesconite

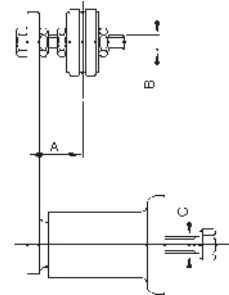
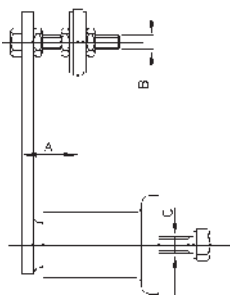

Jednorzędowe

Kod	Typ		ISO	A	B	C	⚖️ kg
F 07123	TECRS 2	3/8" x 7/32"	06 B-1	18 - 35	M 8	M 6	0.30
F 07124	TECRS 3	1/2" x 5/16"	08 B-1	23 - 45	M10	M 8	0.56
F 07125	TECRS 4	5/8" x 3/8"	10 B-1	24 - 44	M10	M 10	0.82
F 07126	TECRS 5	3/4" x 7/16"	12 B-1	30 - 60	M12	M 12	2.17

Dwurzędowe

Kod	Typ		ISO	A	B	C	⚖️ kg
F 07127	TECRS 2	3/8" x 7/32"	06 B-2	25 - 30	M 8	M 6	0.32
F 07128	TECRS 3	1/2" x 5/16"	08 B-2	30 - 34	M10	M 8	0.60
F 07129	TECRS 4	5/8" x 3/8"	10 B-2	34 - 46	M10	M 10	0.90
F 07130	TECRS 5	3/4" x 7/16"	12 B-2	40 - 52	M12	M 12	2.31

Uniwersalny napinacz do pasów Typ TERE

kompletny



Material

Stal/Poliamid

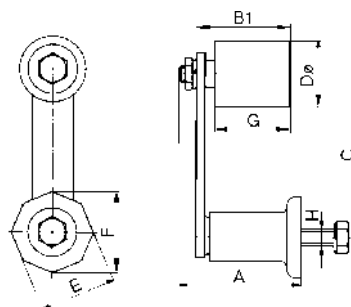
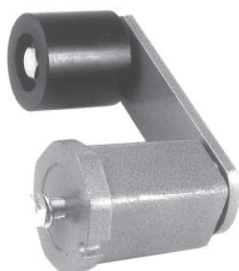

Kod	Typ	A	B1	C	D Ø	E	F	G	H	⚖️ kg
T 37656	TERE 2	61	43	80	30	35	38	35	M 6	0.33
T 37657	TERE 3	70	56	100	40	46	48	45	M 8	0.62
T 37659	TERE 4	88	57	100	40	56	59	45	M 10	0.85
T 37660	TERE 5	122	76	130	60	72	76	60	M 12	2.40
T 37661	TERE 6	158	109	175	80	93	97	90	M 16	4.90
T 37662	TERE 7	211	154	220	80	106	112	135	M 20	8.20

Rozmiary w mm.

UWAGA:

Uniwersalny napinacz dla napędów pasami klinowymi, uzębionymi i płaskimi jest kombinacją uniwersalnego napinacza typu TE i rolki typu RE. Zastosowanie w/w napinacza przedłuża żywotność całego napędu, kompensuje luzy pasa i zapewnia jego równomierną pracę. Poliamidowe rolki są osadzone na kulkowym łożysku o podwyższonej żywotności.

Koło łańcuchowe Typ KS

do napinacza łańcucha

Materiał

Stal

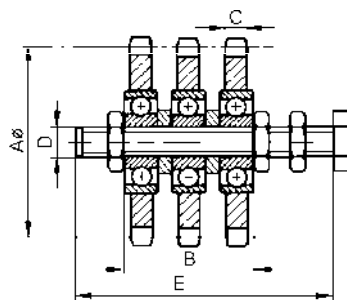
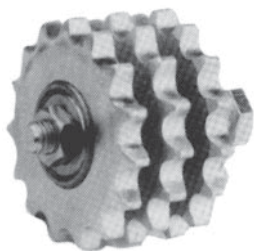

Jednorzędowe

Kod	Typ	Ilość zębów z	A Ø	B	C	D	E	Łańcuch DIN 8187	Ø _g kg
T 31676	KS 3/8 x 7/32" - 10 S	15	45.81	9	5.7	M 10	60	ISO - 06 B-1	0.15
T 31677	KS 1/2 x 5/16" - 10 S	15	61.08	9	7.2	M 10	60	ISO - 08 B-1	0.20
T 31678	KS 5/8 x 3/8" - 12 S	15	76.36	12	9.1	M 12	80	ISO - 10 B-1	0.37
T 31679	KS 3/4 x 7/16" - 12 S	15	91.63	12	11.5	M 12	80	ISO - 12 B-1	0.60
T 31680	KS 3/4 x 7/16" - 20 S	15	91.63	15	11.5	M 20	120	ISO - 12 B-1	0.90
T 31681	KS 1" x 17.02 - 20 S	13	106.14	15	16.2	M 20	120	ISO - 16 B-1	1.30
T 31682	KS 1 1/4 x 3/4" - 20 S	13	132.67	15	18.5	M 20	140	ISO - 20 B-1	2.05
T 31683	KS 1 1/2 x 1" - 20 S	11	135.23	15	24.1	M 20	160	ISO - 24 B-1	2.40

Dwurzędowe

T 31684	KS 3/8 x 7/32" - 10 D	15	45.81	19.2	5.7	M 10	60	ISO - 06 B-2	0.20
T 31685	KS 1/2 x 5/16" - 10 D	15	61.08	22.9	7.2	M 10	60	ISO - 08 B-2	0.35
T 31687	KS 5/8 x 3/8" - 12 D	15	76.36	28.6	9.1	M 12	80	ISO - 10 B-2	0.60
T 31688	KS 3/4 x 7/16" - 12 D	15	91.63	31.5	11.5	M 12	80	ISO - 12 B-2	1.05
T 31689	KS 3/4 x 7/16" - 20 D	15	91.63	34.5	11.5	M 20	120	ISO - 12 B-2	1.35
T 31690	KS 1" x 17.02 - 20 D	13	106.14	46.9	16.2	M 20	120	ISO - 16 B-2	2.10
T 31691	KS 1 1/4 x 3/4" - 20 D	13	132.67	51.5	18.5	M 20	140	ISO - 20 B-2	3.60
T 31692	KS 1 1/2 x 1" - 20 D	11	135.23	63.4	24.1	M 20	160	ISO - 24 B-2	4.25

Trzyrzędowe

T 31693	KS 3/8 x 7/32" - 10 T	15	45.81	29.4	5.7	M 10	60	ISO - 06 B-3	0.25
T 31694	KS 1/2 x 5/16" - 12 T	15	61.08	40.0	7.2	M 12	80	ISO - 08 B-3	0.50
T 31695	KS 5/8 x 3/8" - 12 T	15	76.36	45.2	9.1	M 12	80	ISO - 10 B-3	0.95
T 31696	KS 5/8 x 3/8" - 20 T	15	76.36	48.2	9.1	M 20	120	ISO - 10 B-3	1.25
T 31697	KS 3/4 x 7/16" - 20 T	15	91.63	54.0	11.5	M 20	120	ISO - 12 B-3	1.50
T 31698	KS 1" x 17.02 - 20 T	13	106.14	78.8	16.2	M 20	140	ISO - 16 B-3	2.90
T 31699	KS 1 1/4 x 3/4" - 20 T	13	132.67	88.0	18.5	M 20	140	ISO - 20 B-3	5.20
T 31700	KS 1 1/2 x 1" - 20 T	11	135.23	111.8	24.1	M 20	160	ISO - 24 B-3	6.20

Rozmiary w mm.

W zestawie znajduje się:

Jednorzędowe: koło łańcuchowe, śruba, nakrętka

Dwu,Trzy-rzędowe: koło łańcuchowe, śruba, nakrętka, podkładki dystansowe

Ślizg łańcucha rolkowego typ CRS

do napinacza łańcucha



Materiał

Vesconite

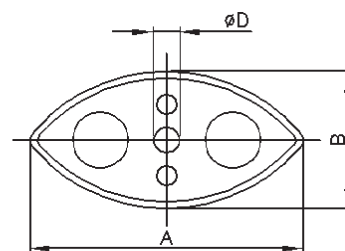
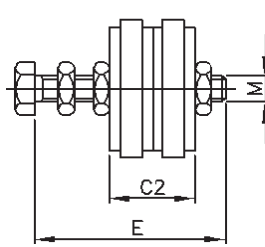
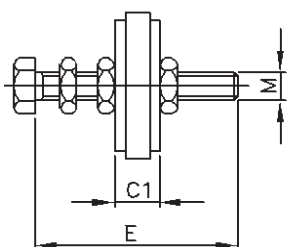

Jednorzędowe

Kod	Typ	Łańcuch		A	B	C1	D Ø	M	E	kg
		Wymiar	ISO							
F 07131	CRS 3/8" - 8	3/8" x 7/32"	06B - 1	74	40	10,2	8	M 8	45	0,05
F 07132	CRS 1/2" - 10	1/2" x 5/16"	08B - 1	96	50	13,9	10	M10	60	0,11
F 07133	CRS 5/8" - 10	5/8" x 3/8"	10B - 1	125	55	16,5	10	M10	60	0,14
F 07134	CRS 3/4" - 12	3/4" x 7/16"	12B - 1	147	80	19,5	12	M12	80	0,22

Dwurzędowe

Kod	Typ	Łańcuch		A	B	C1	C2	D Ø	M	E	kg
		Wymiar	ISO								
F 07135	CRS 3/8" - 8	3/8" x 7/32"	06B - 2	74	40	10,2	20,4	8	M 8	45	0,07
F 07136	CRS 1/2" - 10	1/2" x 5/16"	08B - 2	96	50	13,9	27,8	10	M10	60	0,15
F 07137	CRS 5/8" - 10	5/8" x 3/8"	10B - 2	125	55	16,5	33,0	10	M10	60	0,22
F 07138	CRS 3/4" - 12	3/4" x 7/16"	12B - 2	147	80	19,5	39,0	12	M12	80	0,36

UWAGA:

Kombinacja tworzywowego napinacza typu CRS i uniwersalnego napinacza typu TE daje nam automatycznie napinacz do napędów łańcuchowych.

Walek dociskowy typ RE

do napinacza pasa



Materiał

Poliamid

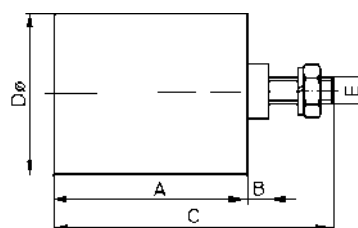
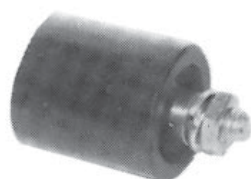

Kod	Typ	A	B	C	D Ø	E	kg
T 37663	RE 2	35	3.0	51	30	M 8	0.075
T 37664	RE 3/4	45	6.0	67	40	M 10	0.170
T 37667	RE 5	60	7.5	89	60	M 12	0.395
T 37668	RE 6	90	9.0	127	80	M 20	1.200
T 37669	RE 7	135	7.0	167	80	M 20	1.700

Rozmiary w mm.

Uwaga:

Kombinacja tworzywowego napinacza typu RE i uniwersalnego napinacza typu TE daje nam automatycznie napinacz do napędów pasowych (pasy: klinowe, zębate, płaskie).

Uniwersalny napinacz Typ TE

Materiał

Stal

RESATEC AG

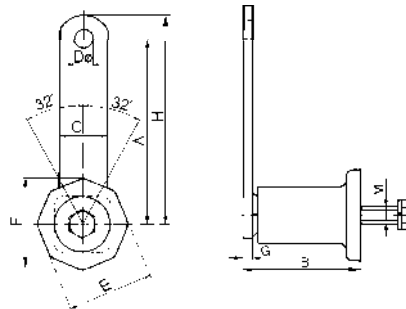

Kod	Typ	A	B	C	D Ø	E	F	G	H	Siła napięcia w N 0 - 32°	M	kg
T 29419	TE 2	80	52	20	8.5	35	38	5	90.0	0 - 90	M 6	0.25
T 29420	TE 3	100	63	25	10.5	46	48	5	112.5	0 - 140	M 8	0.45
T 29421	TE 4	100	78	30	10.5	56	59	6	115.0	0 - 320	M 10	0.68
T 29422	TE 5	130	108	50	12.5	72	76	8	155.0	0 - 820	M 12	1.95
T 29423	TE 6	175	140	60	20.5	93	97	10	205.0	0 - 1500	M 16	3.70
T 29424	TE 7	220	198	70	20.5	106	112	12	255.0	0 - 2500	M 20	6.50

Rozmiary w mm.

UWAGA:

Uniwersalne napinacze Typu TE znajdują zastosowanie przede wszystkim w przekładniach łańcuchowych i pasowych. Za pomocą jednej śruby, mogą być mocowane w każdej pozycji. Napinacze Typu TE są całkowicie bezobsługowe. Pokryte są proszkową ochronną farbą beżową.